

# Short guide

## ME401-2

Version 1.0, May 2013



## Practical advice

### 1. Save important numbers



*Serial number located on the unit*

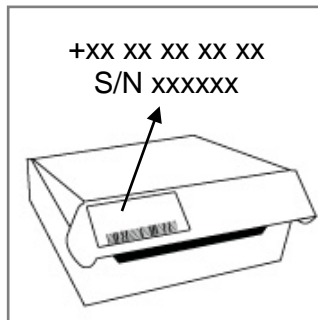

*GSM number and unit serial number is located on the box. Label can be peeled off and saved for later use.*

### 2. Installation is best done outside

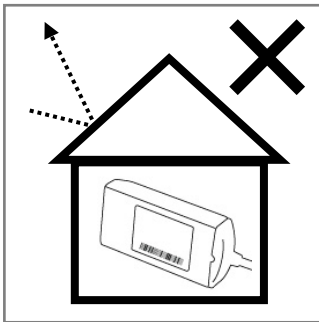

*Do not perform installation inside a building*

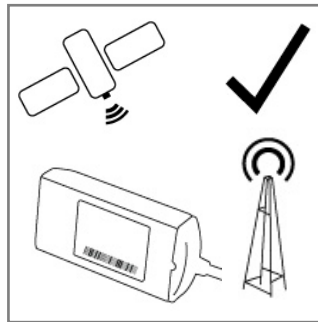

*Install the unit outside for better GPS and GSM signal*

### 3. Correct location of the unit

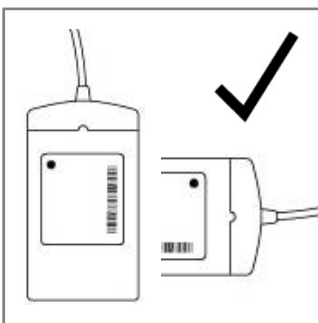

*Locate the unit as shown for optimal signal conditions*

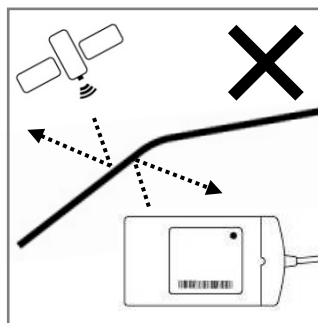

*Avoid installing the unit directly under a layer of metal or next to wires.*

## Installation of the ME401-2 in machinery and vehicles

### Guidelines for correct wiring:

No.	Wire color		Connection	Description
1	Red		Power	Connect to permanent 12/24V supply through a 1A fuse
2	White		Digital input 1	Connect to the operating hours counter <sup>1</sup> <b>Mandatory for machines!</b>
3	Brown		Digital input 2	Connect to the ignition signal <sup>1</sup> <b>Mandatory for vehicles and machines!</b>
4	Grey		Digital input 3	Can be connected to an external sensor or a RFID card reader <sup>1</sup>
5	Pink		Digital input 4	Can be connected to an external sensor for detecting a critical running mode or an alarm <sup>1 4</sup>
6	Green		1-wire input	Can be connected to iButton reader or temperature sensor
7	Yellow		Digital output 1	Can be used to control external equipment through a relay <sup>2 3</sup>
8	Blue		Ground	-

<sup>1</sup> Min. 8V DC voltage at input

<sup>2</sup> Max. Load 200 mA

<sup>3</sup> Do NOT use this output to switch off vehicles and machines during operation or driving

<sup>4</sup> If Main Switch disconnect negative wire (chassis/GND) from battery, it might cause false input activity. To avoid that, Pink wire should be connected to the chassis/GND, Blue Wire should be connected to battery minus pole and input filtering must be activated (see page 4)

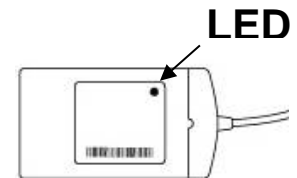

### Functionality check: LED on the unit

Status	LED mode	LED color	Status indication
✓	Red flashing light and constant green light in LED		GSM network is OK and GPS has valid satellite position
!	No light in LED		No power supply
!	Constant red light and no green light in LED		Power supply is OK but NO GSM network GPS has NO satellite position
!	Red flashing light and no green light in LED		GSM network is OK GPS has NO satellite position
!	Constant red and green light in LED		Power supply is OK but NO GSM network GPS has valid satellite position

### Verification of installation status with SMS Commands:

Verification	Send SMS	Return SMS from unit
<b>GPS and GSM signal</b>	<i>MT SIGNAL</i>	<p>MTC ACK (SERIAL No.) SIGNAL: GSM=22, SAT=8, SN=44</p> <p><b>Poor</b>      <b>Good</b>      <b>Excellent</b></p> <p><b>GSM: Signal strength:</b></p> <p>0-10 → 11-20 → 21-31</p> <p><b>SAT: Number of satellites:</b></p> <p>0-3 → 4-5 → 6-</p> <p><b>SN: GPS signal quality:</b></p> <p>0-27 → 28-34 → 35-</p>
<b>Inputs</b>  <i>NOTE: This command can be sent to the unit under various operational conditions like: Machine running, ignition only or off.</i>	<i>MT STAT</i>	<p>MTC ACK (SERIAL No.) INPUT STATUS: INPUT1 LOW, INPUT2 HIGH, INPUT3 LOW, INPUT4 LOW, CHARGE VOLTAGE ON, SERIAL No.</p> <p><b>NOTE:</b>  <b>Input LOW &lt; 8V &lt; input HIGH</b></p>

### Activation of input filtering

Function	Send SMS	Return-SMS from the unit
Activate filter function on inputs	<i>MT INFILT ON</i>	MTC ACK (SERIAL No.) INFILT ON

**NOTE:**

Enabling the filtering function will disable the use of the alarm function on digital input 4.





## Troubleshooting

Error description	Possible solutions
No reply on SMS command	<ul style="list-style-type: none"> <li>• Verify correct GSM number</li> <li>• Check LED status – see page 3</li> </ul>
No light in LED	<ul style="list-style-type: none"> <li>• Check if red wire and blue wire are installed correctly or if fuse is blown</li> </ul>
Constant red light in LED	<ul style="list-style-type: none"> <li>• Verify location of the unit – see page 2</li> <li>• Move machine or vehicle for better GSM signal</li> </ul>
No green light in LED	<ul style="list-style-type: none"> <li>• Verify location of the unit – see page 2</li> <li>• Move machine or vehicle for better GPS reception</li> </ul>
Inputs counting operating hours when machine is off	<ul style="list-style-type: none"> <li>• In case the main switch on the machine will disconnect the negative wire (Ground wire), the inputs may register a voltage level and start counting operating hours</li> <li>• To avoid this situation the digital input 4 (Pink wire) should be connected to the chassis/ground on the machine</li> <li>• Send MT INFILT ON to the unit (SMS to phone number) to activate the filtering</li> </ul>



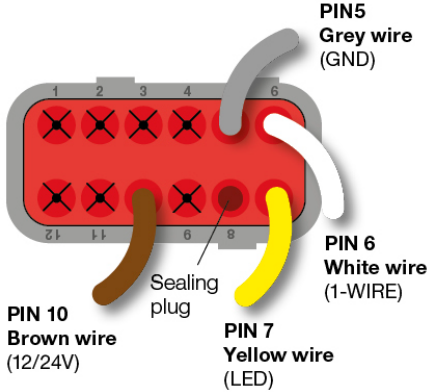

***Please contact your Trackunit dealer if problems continue. Please have the unit serial number ready.***

## Accessories

### Trackunit iButton Reader:

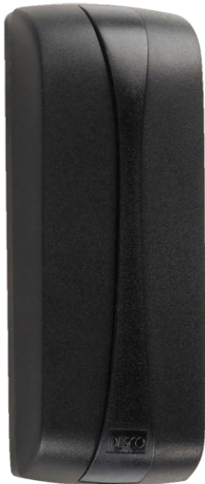
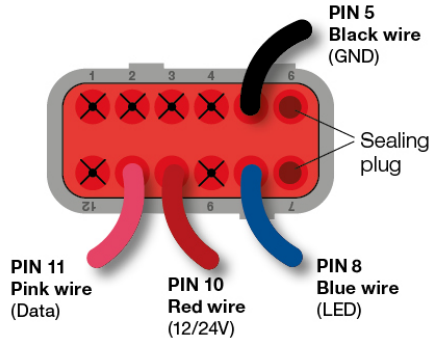
iButton Reader		iButton Reader connections	
			
iButton keys	Terminals	Relay	
			

### Trackunit RFID Reader:

RFID Reader		RFID Reader connections	
			
RFID card	Terminals	Relay	
			

**Connector assembly:**

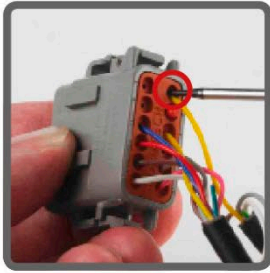

*Step 1:*  
Push contacts into the connector grommet until it **CLICKS**.

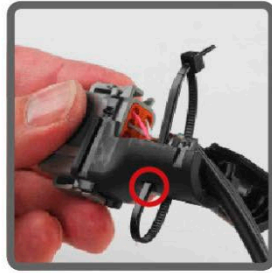

*Step 2:*  
Put the connector into back shell and use strips for fixating the wires. Cut off unnecessary strip.



*Step 3:*  
Close the connector back shell until it **CLICKS**. Avoid squeezing wires.



*Step 4:*  
Insert orange wedge until it **CLICKS**.

**Connector removal:**  
(Reader replacement)

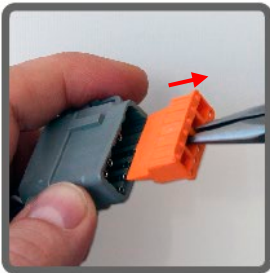

*Step 1:*  
Pull out orange wedge.



*Step 2:*  
Remove contacts with a gentle pull while releasing the locking finger with a screwdriver.

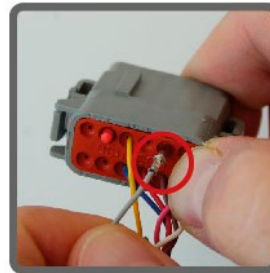

*Step 3:*  
Hold the connector with your finger and gently pull out the contact.

**Relay: (immobilizer)**

OUT1 must be connected to the relay. Verify relay voltage specifications complies with the machine or vehicle voltage (12V or 24V).

Relay	Function	Signal
86	Relay Coil +	12/24V permanent power
85	Relay Coil -	Yellow wire from ME401 (OUT1)
87	Starter Control Signal	
30	Signal to starter motor	

Relay connections:

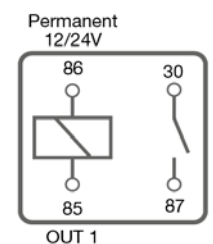

## Product specifications

The ME401 unit is a GSM/GPRS quad-band-unit with GPS, integrated antennas and backup battery.

Connections	
Operational voltage (supply voltage):	12 - 24 V DC
Absolute maximum voltage range:	6 - 50 V DC

Temperature range	
Operating	-30°C to +60°C
Storage	-40°C to +70°C

Mechanical specifications	
Environmental class	IP67

## Technical Assistance

If you have a problem and cannot find the information you need in the product documentation, please contact Trackunit A/S

Trackunit A/S  
 Industrivej 10  
 DK-9490 Pandrup  
 Tel: +45 96 73 74 00  
 Fax: +45 96 73 74 07

E-mail: [support@trackunit.com](mailto:support@trackunit.com)

Web: [www.trackunit.com](http://www.trackunit.com)

**NOTE:** When contacting technical support, please have the unit serial number ready.